

SHO-ME HORSE SHOW CIRCUIT POINT SYSTEM

POINT SYSTEM

Championship awards will be given on the basis of the Point System, 5-4-3-2-1 for first, second, third, fourth, and fifth place. All nominated horses will receive one point in each class that is physically entered. Plus, those placing receive the normal points as seen above. At the end of the show season, qualifying points won by each horse or rider will be totaled by the Points Secretary, Directors and Officers and winners will be determined.

TIES

In the event of a tie, year end awards will be given to the first five highest point earners.

YEAR END AWARDS

An Annual Exhibitor Banquet will be held to present year end awards. The date, time and place will be announced after the final show of the season. At this banquet awards will be given to the five high point horses or exhibitors in each division. For more information, call or write any of the Officers, Board Members or Club Representatives.

MISSOURI LIABILITY LAW

Under Missouri law an equine professional is not liable for an injury to or the death of a participant in equine activities resulting from the inherent risks of equine activities pursuant to the Revised Statutes of Missouri

CHAMPIONSHIP DIVISIONS

If any of the below classes are offered at a Sho-Me Circuit Show, it is mandatory that they be counted as point classes and governed by Sho-Me Circuit Rules. Should a rule be questioned at a show, the board members have the final ruling. If their decision is not followed, that show will lose its right to have their points counted.

- Stock Type Halter 2 & Under
- Stock Type Halter 3 & Over
- Youth Halter
- Appaloosa Halter
- Arabian/Saddle Type Halter
- Novice Showmanship
- Showmanship, Adult (19 years & over)
- Showmanship, Youth (18 years & under)
- Yearling Longe Line (any breed)
- Lead Line (rider 9 years & under)
- Adult Western Pleasure (19 yrs & over)
- Arabian/Saddle Type Western Pleasure
- Green Horse Pleasure
- Junior Western Pleasure (5 years & under)
- Open Bareback Pleasure
- Open Novice Western Pleasure (rider 19 yrs & over)
- Open Western Pleasure
- Pony Pleasure (Walk & Trot/Favorite Gait ONLY)
- Senior Western Pleasure (horse 6 years & over)
- Snaffle Bit Western Pleasure, 2 & 3 Year Old
- Walk Trot Pleasure (13 & Under)
- Walk Trot Pleasure (14 - 18)

Walk Trot Pleasure (19 & Over)
Walk Trot Novice Pleasure
Youth Western Pleasure (18 years & under)
Horsemanship/Equitation, Youth (18 & Under)
Horsemanship/Equitation, Adult (19 & Over)
Novice Walk-Trot Horsemanship/Equitation
Walk Trot Equitation (13 & Under)
Walk Trot Equitation (14 – 18)
Walk Trot Equitation (19 & Over)
Open Costume
Open Driving
Open Egg & Spoon
Open English Pleasure
Open Reining (AQHA RULES)
Open Trail
Ranch Reining
Open Flag Race
Adult Barrels (19 years & over)
Adult Pole Bending (19 years & over)
Youth Barrel Race (18 years & under)
Youth Pole Bending (rider 18 years & under)

THE FOLLOWING ARE THE RULES FOR THE SHO-ME CIRCUIT HORSE SHOWS

Rules of the American Quarter Horse Association (AQHA) will be followed for all classes unless otherwise noted in the following show rules. Breed specific rules will be used for those classes which AQHA does not apply. Saddle clubs hosting a show must have the latest edition AQHA Handbook present at the show for reference. Exhibitors should be familiar with AQHA rules and Sho-Me Circuit's exceptions to these rules. Judges are encouraged to judge open all breed classes to the breed specific standards. An AQHA and USEF rule book will be available at each show. AQHA Rules can be found at www.aqha.com. USEF Rules can be found at www.usef.org.

ATTIRE

In all classes except English pleasure, horsemanship/equitation, costume and driving, it is mandatory to wear appropriate western attire; including western hat/helmet, boots with heels, and a long sleeved (to the wrist) collared shirt. For personal safety, it is recommended that protective helmets be used in all events. Chaps are optional.

UNSPORTSMANLIKE CONDUCT

Any act of discourtesy or disobedience to a judge, Sho- Me Circuit official or a member show official by an owner, exhibitor, agent, employee or family member shall be deemed to constitute unsportsmanlike conduct. The Sho-Me board of directors can suspend the rights of the exhibitor from participating in any Sho-Me Circuit show, and that exhibitor will forfeit all points for a determined period of time.

DISQUALIFICATION/DISCIPLINARY ACTION

When an exhibitor and/or his/her representative acting on behalf of the exhibitor with the exhibitor's consent, is guilty of unsportsmanlike conduct, or inhumane treatment of a horse, the Sho Me Circuit Association can suspend the rights of such exhibitor and representative(s) to participate in the current show and in further approved shows and forfeit all points for such a period of time as judges appropriate by the Board of Directors. Any suspension or other disciplinary action will be imposed in an incremental fashion and will be done with full knowledge of the Sho Me Circuit officers and board members and full disclosure to the offender.

CONTROL OF HORSES

Horses not under control or threatening the safety of riders may be called to the center of the arena or asked to leave the class. The judge may let the other horses continue on the rail or halt as necessary. Horse/riders outside the arena should conduct themselves in a courteous manner so that not to endanger horses or spectators.

PROBLEMS NOT COVERED BY RULES

Problems not specifically covered by these rules shall be decided by the Sho Me Circuit officers and board members. Individuals should contact the designated show representative with any questions or concerns regarding a particular Sho Me Circuit show. All decisions of the Officers and Board members will be final.

SPEED EVENTS

NO RUNNING IN OR OUT OF THE ARENA. For safety, all speed events will start and stop inside the arena gate.

DISABLED EXHIBITORS

With the approval of the judge prior to the class, disabled exhibitors may have assistance as needed.

EXHIBITOR NUMBERS

An exhibitor wearing no number or the wrong number will be disqualified for that class. Numbers may be worn on the exhibitor's back OR on BOTH SIDES of the saddle pad.

PROOF OF HORSES AGE OR BREED

Should a question arise concerning the age or breed of a particular horse, it shall be the responsibility of the exhibitor to show proof of age or breed for that horse.

HORSE HEALTH

Any horse showing evidence of lameness, illness or signs of raw or bleeding sores about the legs, feet or mouth shall be disqualified at the discretion of the judge.

PROTECTIVE HEAD GEAR

Protective head gear is allowed in any class. Riders will not be penalized for not wearing a Western or English hat if they are wearing protective head gear.

MULTI-CIRCUIT SHOWS

Any class designated as a Sho-Me Circuit class shall be governed by the Sho-Me Circuit Rules, as set in this list.

STALLIONS

No stallions are allowed in any youth class, and no one under the age of 19 shall be allowed to show a stallion in any class, unless the stallion is a weanling.

CLASSES:

HALTER CLASSES

Appaloosa Halter, Arabian/Saddle Type Halter, Youth Halter, Stock Type Halter 2 & Under and Stock Type Halter 3 & Over to be judged separately on conformation, eye appeal and way of going.

Stock Type Halter 2 & Under and Stock Type Halter 3 & Over *MAY* be combined at a show if *ALL* exhibitors agree.

Arabian/Saddle Type Halter will include all saddle type breeds, including; Arabian, Morgan, Saddlebred and National Show Horse.

Youth Halter will be exhibitors 18 years and under only.

YOUTH SHOWMANSHIP AT HALTER

Open to exhibitors 18 years old and under. AQHA rules apply.

ADULT SHOWMANSHIP AT HALTER

Open to exhibitors 19 years old & over. AQHA rules apply.

NOVICE SHOWMANSHIP

Rules will follow those of the showmanship classes already offered except the class will be open to first and second year exhibitors in the Sho-Me Circuit who have never shown in a showmanship class.

YEARLING LONGE LINE

The purpose of showing on a longeline is to demonstrate that the horse has the movement, manners, expression, attitude and conformation to become competitive under saddle. Conformation of the class should be judged with its suitability as a future performer under saddle in mind. Judging conformation will occur prior to the longeing. Each entry will be walked to the judge and pause for evaluation individually. They will then trot off straight and around a cone to the rail where they will wait for the lounging portion.

Longeing will be given 90 seconds and will have a start signal, a half-way signal, and end signal. Each horse must work at a walk, trot and lope/canter both directions. Each gait must be shown long enough for judge evaluation. The yearling must be shown in a halter, regular or show type. Longe line not to exceed 30' and attached to the halter, must hang free and not touch the horse. No chains under the chin or over the nose. A longe whip may be used, but exhibitor will be disqualified for striking the horse. NSBA rules apply, and the judge is required to use a NSBA Score Sheet to be posted at conclusion of the class. Score Sheet will be provided by Sho-Me if the judge does not have one.

PONY PLEASURE (Walk & Trot/Favorite Gait ONLY)

Open to riders 18 years old and under. Ponies shall be 56 inches and under the class is to be shown at walk and trot or favorite gait. No stallions will be allowed. Ponies may be shown in English or western tack. If the height of a pony is questioned, the size shall be verified by a Sho-Me Circuit board member.

LEAD LINE CLASS

This class is open to riders 9 years old and under who do not compete in any other riding class. Any type of horse or pony may be shown, no stallions. The horse must be led and controlled by an adult over the age of 16. The class will be worked at a walk only, in both directions of the ring. In the line-up, the judge may ask riders to back their horses to help them judge the extent of the rider's horsemanship. The rider will be judged on the basic position in the saddle, hand, leg, seat and back position. A lead shank at least six feet long must be attached to the shank of the bit or the halter that is under the bridle so the horse is

controlled by the adult. If the judge asks the rider to back the horse in the line-up, the adult should not aid the rider. The adult should only keep the horse under control. The rider may ride Western or English in this class. The person leading the horse should be in appropriate show attire. A fancy outfit will not count over a neat working outfit. There is no minimum age for any youth contestant in the Lead Line Class. No rider will be allowed to be tied, buckled or fastened in the saddle in any manner.

WALK TROT EQUITATION

This class is divided by age (13 & Under, 14 – 18, 19 & Over). Age Divisions 13 & Under and 14 -18 may be combined by the show committee if ALL EXHIBITORS agree at the show.

The class is judged 100% on the rider's horsemanship. Horses will work at a walk and trot in both directions of the arena. Rider will be judged on their basic position in the saddle, hand, leg and back position. Exhibitor will also be judged on how well they control their horse. No stallions allowed to be exhibited by anyone under the age of 19 in this class. Riders may show in English or Western tack and attire. Pattern: At discretion of the judge.

WALK TROT PLEASURE

This class is divided by age (13 & Under, 14 – 18, 19 & Over). Ag Divisions 13 & Under and 14 -18 may be combined by the show committee if ALL EXHIBITORS agree at the show.

This class is judged on the horse's performance. Riders may show in English or western tack and attire.

NOVICE WALK-TROT PLEASURE

Riders of any age may enter this class. The riders are eligible during their first or second year in showing in the Sho-Me Circuit (excluding Lead-line and in hand classes only).

NOVICE WALK TROT EQUITATION

Riders will be judged at the walk & trot on the rail only. Riders of any age may enter this class. The riders are eligible during their first or second year in showing in the Sho-Me Circuit (excluding Lead-line and in hand classes only).

YOUTH HORSEMANSHIP/EQUITATION

This class is open to exhibitors 18 years and under riding any breed of horse or pony over the size of 46 inches. No stallions. Riders may show in English or western tack and attire. Rail work will be done at the discretion of the judge. AQHA rules apply.

ADULT HORSEMANSHIP/EQUITATION

Open to riders 19 years old and over. May be shown in English or western tack and attire. Rail work will be done at judge's discretion. AQHA rules apply.

ARABIAN/SADDLE TYPE WESTERN PLEASURE

Open to Saddle Type breeds, including; Arabians, Morgans, Saddlebreds, National Show Horses. Horses must be 14 hands and over. Riders of any age may enter this class. The horses are to be shown with western equipment. Junior horses (5 years and under) may be shown with a snaffle bit or bosal. Appointments to be in accordance with USEF rules. Rider to be dressed in western attire. Horses to be shown both ways of the ring at a walk, jog trot and canter. Hand gallop may be called for as an optional gait, extreme speed to be penalized. Horses will be required to back. Horses to be judged on manner and performance.

OPEN NOVICE WESTERN PLEASURE

Riders of any age may enter this class. The riders are eligible during their first or second

year in riding classes in the Sho-Me Circuit excluding lead-line, walk-trot and in-hand classes only.

GREEN HORSE PLEASURE

Riders of any age may enter this class, but the HORSE of any age or breed must be in their first or second year of showing under saddle.

YOUTH WESTERN PLEASURE

Riders shall be 18 years old and under. Each club shall have the option to show two divisions (a) 13 years and under and (b) 14 thru 18 years. If only one class is offered it must be for ages 18 years and under. No stallions allowed in this class.

SENIOR WESTERN PLEASURE

Open to all horses 6 years of age or older. The exhibitor may be any age.

JUNIOR WESTERN PLEASURE

Open to all horses 5 years of age or under with any age exhibitor. The horse may be shown with bit, bosal or snaffle.

OPEN WESTERN PLEASURE

This class is open to all horses of any breed. Riders must be at least 6 years old to enter this class.

2 AND 3 YEAR OLD SNAFFLE BIT WESTERN PLEASURE

Only 2 or 3 year old horses are allowed to show in this class. Horses may be shown with bosal or a snaffle bit and two hands must be used on the reins. If shown with a snaffle bit, the bit ring should be no larger than 4 inches and no smaller than 2 inches. Mouth piece must be no smaller than 3/8 inch in diameter. If showing with a bosal, the diameter should be no larger than 3/4" at the cheek. AQHA rules will apply.

ADULT WESTERN PLEASURE

Riders shall be men or women 19 and over. Horses of any breed may show in the class.

OPEN COSTUME CLASS

Open to any breed or size of horse and any age rider. Horses or ponies horses can be ridden or led. Horses to be shown at walk. This class is to be judged on creativity, originality of the costume and manner of the horse. Class may be divided into two divisions at the option of the clubs. If divided the division will be (a) 18 years and under and (b) 19 years old and over.

OPEN DRIVING

Open to all breeds, or types of horses and ponies. The judge should realize that each breed will have different standards and each horse or pony should be judged accordingly. A driving horse should carry himself in a natural balanced position. Maximum credit should be given to a horse/pony that moves straight, with free movement, manners and bright expression. The driving horse/pony shall be severely penalized if he carries his head behind the vertical, is over flexed, excessively nosed out; the poll is below the withers, or exhibits lack of control by the exhibitor. This class is to be judged 80% on the performance and suitability for assuring a pleasurable drive, with a maximum of 20% on condition and conformation. Horses/ponies will NOT be asked to back. Gaits to be shown in both directions at the walk (flatfooted), park gait (jog) and road gait (extended trot). Reverse will be on the diagonal, and at the walk. Equipment required for the driving class shall include a whip, collar or breast collar with a standard driving bridle. Over check, or side checks permitted, at the option of exhibitors. To be shown in a suitable 2 or 4 wheel single horse vehicle suitable to be driven by a single horse/pony. Open to all age exhibitors, one passenger permitted with adults. Children 18 & under are required to have an adult passenger. Headers are optional for adults, mandatory for youth and must be an adult. Headers can also be the adult passenger.

OPEN ENGLISH PLEASURE

Open to any breed or size horse with any age rider. The horse is to be shown at walk, trot, and canter in both directions of the arena. Proper tack and attire must be used for the type of seat chosen. The judge has the option of eliminating the requirement for participants to wear a jacket in extreme heat. The horses in this class may be asked to back. Each breed should be judged according to the specific standards of that breed.

OPEN BAREBACK PLEASURE

Open to any horse or pony with any age rider. Horses to be shown at walk, trot, and canter both directions of the arena. Horses may be asked to back.

OPEN EGG AND SPOON

Open to all horses and riders. Riders to be furnished with eggs and uniform spoons. Gaits to be called at the discretion of the judge. Riders not complying with judge instructions will be disqualified. The rider shall not be asked to ride outside the saddle nor will the rider be required to drop the reins and relinquish the control of their horse. The last rider retaining an egg will be the winner.

OPEN TRAIL

The purpose of Open Trail is to demonstrate the useful working ability of the horse, using obstacles one would encounter in a normal day. To be judged on how well the horse responds to the rider's commands and how punctually he performs the tasks, not how quickly, but how smoothly the team of horse and rider perform the posted pattern.

Obstacles: Any SAFE obstacle may be used to demonstrate the horse's ability. Some simple standards of safe and unsafe are below:

SAFE:

1. Working over poles on the ground
 - A. Walk-over: 20"-24" between poles
 - B. Trot-over: 3'-3'6" between poles
 - C. Lope-over: 6'-7' between poles
2. Bridge (can be as simple as a piece of plywood)
3. Gate (can use just two poles/jump standards and a rope, but must be big enough to get a horse through)
4. Sidepass a pole
5. Mailbox
6. Slicker (carry from point A to B)
7. Back thru (either straight or an L); minimum of 28" wide
8. 360 degree turn in a box 5'-7' distance
9. Walk or trot through a series of cones, 6' minimum between cones

UNSAFE:

1. Tarps
2. Rocking bridges
3. Shower curtains

Patterns: Pattern should contain at least 3 obstacles. Gaits between may be walk, trot, or lope, but pattern must contain two different gaits (i.e. walk and trot). Show committee or judge may make the pattern, but it must be posted at least 1/2 hr. prior to showing. Judge will have final say on course design to ensure safety and judge-ability of this class.

Judging: Judging to be on the combination of horse and rider and how well they perform together over the pattern. Shows are encouraged to use the "3 and move on" (if competitor has 3 refusals at one obstacle they should move on) philosophy to keep the show moving smoothly. A DQ will result from not performing the obstacles in the correct order. Three refusals at an obstacle will be a 0 on that obstacle. Lesser refusals to be judged accordingly.

OPEN REINING

To rein a horse is not only to guide him, but also to control his every movement. The best reined horse should be willingly guided or controlled with little or no apparent resistance and dictated to completely. Any movement on his own must be considered a lack of control. All deviations from the exact written pattern must be considered a lack of or temporary loss of control, and therefore faulted according to severity of deviation. Credit will be given for smoothness, finesse, attitude, quickness and authority in performing the various maneuvers while using controlled speed.

Any one of the 12 AQHA-approved reining patterns may be used and is to be selected by the judge of the class and used by all contestants in the class.

Each contestant will perform the required pattern individually and separately. All horses will be judged immediately upon entering the arena. Any fault incurred prior to the commencement of a pattern will be scored accordingly.

Scoring will be on the basis of 0-Infinity, with 70 denoting an average performance. The individual maneuvers are scored in ½ point increments from a low of -1 1/2 to a high of +1 1/2 with a score of 0 denoting a maneuver that is correct with no degree of difficulty.

RANCH REINING

This class denotes the ability for the Ranch or reining horse to be reined willfully through all maneuvers of the patterns. Contestant should not be penalized for reining their horse through the pattern in a reasonable manner. Stops should be hard and deep as if needed to stop and go in the other direction. Stop should be square and done without resistance. Sliding stops will not be penalized, and may be given maneuver credits at the judge's discretion. Turn a rounds should be those of a working horse. They should be correct, but job efficient. Judge will choose from one of the three approved patterns, which will be posted at no less than 30 minutes prior to the start of the class.

Penalty Points:

½ Point:

- Failing to remain more than 20 feet from the fence when stopping or performing a rollback.
- Starting a lope departure at a jog or exciting rollbacks up to 2 strides.
- Delaying changes of lead by 1 stride.
- Over or under spinning by one-eighth (1/8) turn.

1 point:

- Delaying change of lead from start to one-fourth (1/4) circle (up to a maximum of 4 penalty points).
- Over or under spinning by one-fourth (1/4) turn.
- Failure to be on the correct lead in run-about.

2 points:

- Break of gait
- Delaying change of lead from start to half (1/2) circle.

- During the run to the end of arena, failure the change leads prior to next maneuver.
- Jogging beyond 2 strides, but less than (1/2) circle or half (1/2) the length of the arena.
- Failure to go beyond the markers.
- Freezing up in spins or rollbacks.

5 points:

- Spurring in front of the cinch.
- Use of free hand to install fear.
- Holding saddle with free hand
- Kicking out

0 Score:

- Failure to complete pattern
- Performing maneuvers in unspecified order.
- Inclusion of additional maneuvers
- Equipment failures
- Balking or running away.
- Jogging more than half (1/2) circle or half (1/2) arena length while starting a circle.
- Over spinning of more than one-fourth (1/4) turn
- Fall to ground by horse or rider
- More than one finger between reins or more than one hand on reins except for junior horses ridden with snaffle, hackamore or mecate with snaffle.
- Blatant disobedience, bucking, rearing, etc.

Faults not to be considered disqualification but should be scored according to severity:

- Crooked stops & backs.
- Knocking over markers
- Anticipating stops
- Failure to run patterns within markers
- Uncontrollable speed
- Failure to go past markers on said patterns
- Wringing of tail
- Opening mouth, rising head on stops & turns.

RANCH REINING PATTERNS:

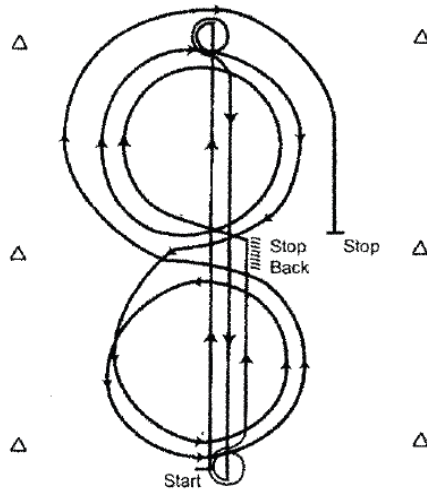

Pattern #1

1. Run to far end of arena.
2. Stop, 1 ½ turn to left
3. Run to far end of arena, Stop
4. 1 ½ turn to right.
5. Run past middle marker, Stop and back to middle marker
6. ¼ turn to left, 2 circles to the right, 1st small and slow, 2nd large and fast
7. Change leads at center of arena, 2 circles to left, 1st small and slow, 2nd large and fast
8. Change leads at center of arena. Start a circle to the right, Stop at middle marker before completing the circle.

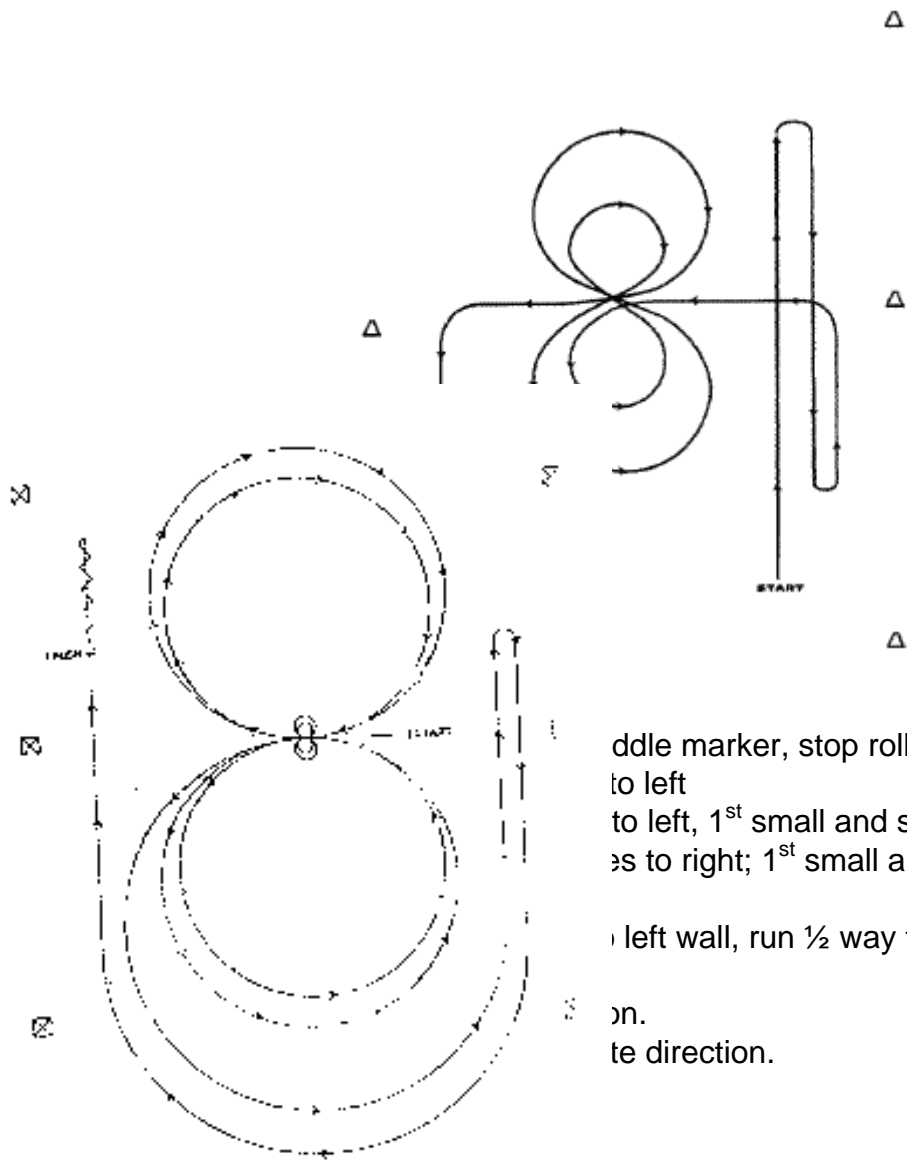

middle marker, stop roll back to right.
 to left
 to left, 1st small and slow, second large and fast.
 es to right; 1st small and slow, second large and
 left wall, run 1/2 way to far marker.
 on.
 te direction.

Pattern #3

Horses may walk or trot to the center arena. Horses must walk or stop prior to starting the pattern. The pattern begins at the center of the arena facing the left wall or fence.

1. Beginning on the left lead, complete 2 circles to the left. Stop at the center of the arena facing the left wall or fence.
2. Complete 2 spins to the left. Hesitate.
3. Beginning on the right lead complete 2 circles to the right. Stop at the center of the arena. Hesitate.
4. Complete 2 spins to the right. Hesitate.
5. Beginning on the left lead, go around the end of the arena, run down the right side of the arena past center marker, stop and roll back right.
6. Continue around the end of the arena to run down the left side of the arena past the center marker. Stop. Back up.

SPEED EVENTS

Long pants and boots with heels are required for all speed events. Helmets and hats are not required, but helmets are strongly recommended. An exception to AQHA rules allows the use of plastic, metal, or rubber barrels in Sho-Me Circuit speed events.

Starting line markers or electric timers shall be placed, when at all possible, against the arena fence. An electric timer or at least two watches shall be used, with the time indicated by the electric timer or average time of the watches used by official timers to be the official time. When an electric timer is used, the following apply: If a contestant makes a qualifying ride but the timer fails, the contestant automatically gets a re-ride which will be the time for the event.

No horse shall be allowed to show more than once in each speed event per show for points.

ADULT POLE BENDING

This class is for riders age 19 & over. Each pole knocked over adds a 5 second penalty. AQHA rules apply.

YOUTH POLE BENDING

Riders 18 years and under or class may be split into (a) 13 and under or (b) 14 thru 18 years old. AQHA rules apply.

YOUTH BARREL RACE

Knocking over a barrel shall carry a five-second penalty. Failure to follow the course shall cause disqualification. A contestant may touch the barrel with his/her hand in barrel racing. Starting line markers or electric timers shall be placed, when at all possible, against the arena fence. An electric timer or at least two watches shall be used, with the time indicated by the electric timer or average time of the watches used by official timers to be the official time. When an electric timer is used, the following apply: If a contestant makes a qualifying ride but the timer fails, the contestant automatically gets a re-ride which will be the time for the event. Knocking over extra barrels will be subject to five-second penalties, or failure to run the pattern will be cause for disqualification. In the event of a tie, the horse declared the winner in the run-off must rerun the pattern within two seconds of its original time or the run-off must be held again. Penalty will not apply to the two-second rule but will apply to the final run-off time.

Rider is 18 years and under inclusive or may be split into (a) 13 years and under and (b) 14 thru 18 years of age.

ADULT BARREL RACE

Rules same as Youth Barrel Race, except rider shall be 19 years old and over.

OPEN FLAG RACE

This is a timed event. An electric timer or two watches are to be used (average time is to be the official time). Failure to go around pick-up point, pick up flag from buckets or failure to place flag in an open ended barrel will be considered "No Time." Contestants can start or finish to the left or right side of drop point, except there is NO crossing over permitted between the pick-up and the drop point. If the contestant crosses over, this will be considered a broken pattern and contestant will be disqualified.

YOUTH & ADULT VERSATILITY

The show rules for the Sho-Me Circuit apply to all individual classes as published in the circuit directory. The point system will be consistent with that published in the circuit directory.

- To be eligible, the youth or adult must show in at least one half of the Sho-Me approved shows during the current year.
- The youth or adult must indicate on their Nomination Form they wish to be considered for the Versatility Award.
- The youth or adult must show in and qualify for a year end award in at least one class from each of the following divisions.

<u>YOUTH DIVISION</u>	<u>ELIGIBLE YOUTH CLASSES</u>
<u>Equitation</u>	Youth Showmanship Youth Horsemanship Youth Walk-Trot Equitation (13&Under & 14&Over)
<u>Pleasure</u>	Youth Western Pleasure Youth Walk-Trot Western Pleasure (13&Under & 14&Over)
<u>Games</u>	Youth Barrel Race Youth Pole Bending
<u>ADULT DIVISION</u>	<u>ELIGIBLE ADULT CLASSES</u>
<u>Equitation</u>	Adult Showmanship Adult Horsemanship Adult Walk-Trot Equitation (14 & Over)
<u>Pleasure</u>	Adult Quarter Type Western Pleasure Walk Trot Western Pleasure (14 & Over)
<u>Games</u>	Adult Barrel Race Adult Pole Bending

- All points accumulated from any of the Championship classes will be counted toward the Youth or Adult Versatility Award, even if the exhibitor does not show in a specific class often enough to qualify for a year end award.
- Points will be accumulated on a one horse/one rider combination.